

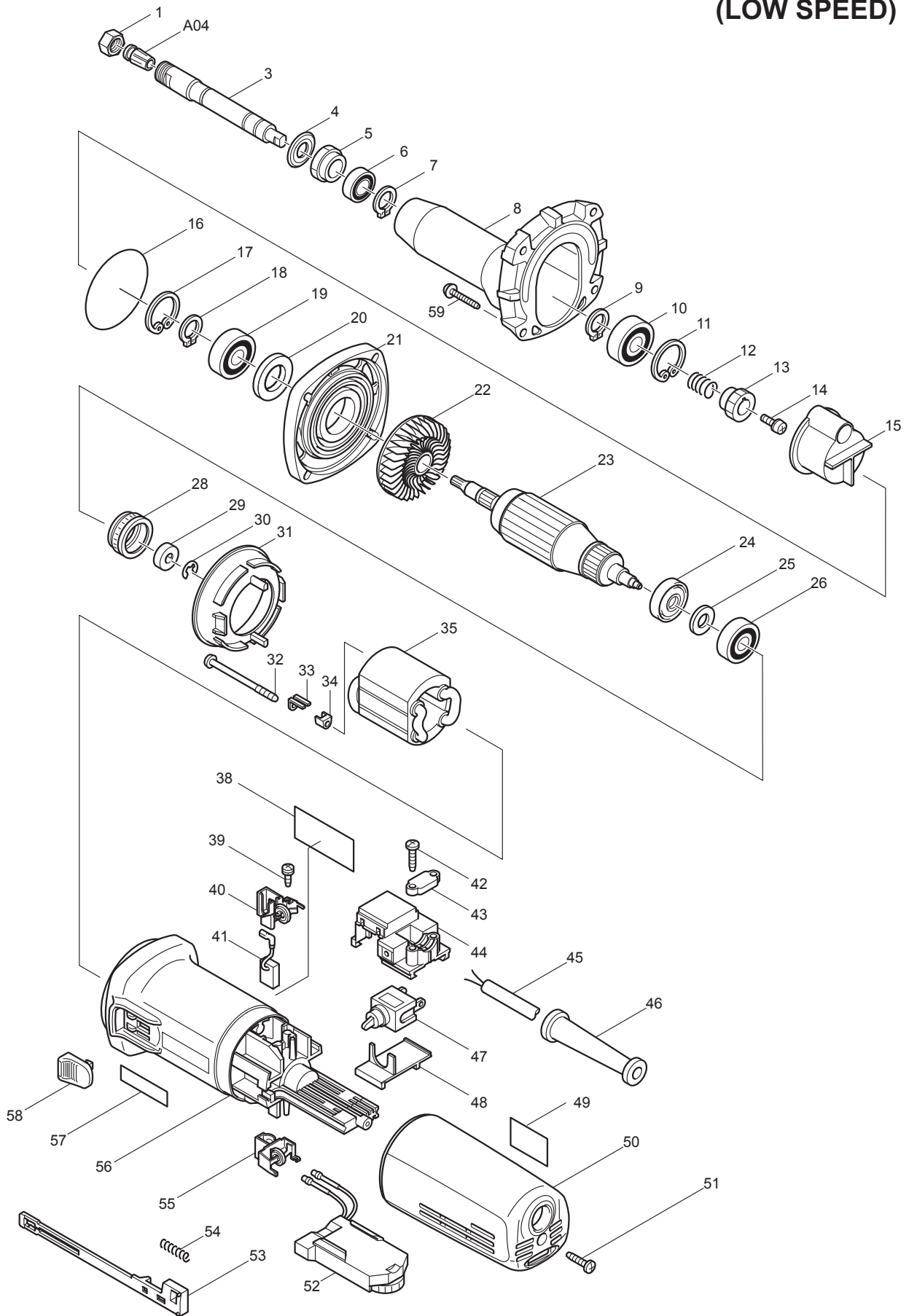

07 - 2010
GD0810C
1/4" DIE GRINDER
(LOW SPEED)



Item No	Type	Sub	Part No	Description	Qty	Unit
001			763645-2	COLLET NUT	1	PC.
003			324042-3	SPINDLE	1	PC.
004			213209-7	OIL SEAL 16	1	PC.
005			285700-5	BEARING RETAINER	1	PC.
006			211141-9	BALL BEARING 6901LLB	1	PC.
007			961052-5	RETAINING RING S-12	1	PC.
008			317369-8	BARREL	1	PC.
009			961052-5	RETAINING RING S-12	1	PC.
010	2		211148-5	BALL BEARING 6001ZZ	1	PC.
011			962106-1	RETAINING RING R-28	1	PC.
012			233901-9	LOCK SPRING 12	1	PC.
013			226531-3	HELICAL GEAR 25	1	PC.
014			265082-1	PAN HEAD SCREW M4X8	1	PC.
015			417363-1	GEAR COVER	1	PC.
016			213611-4	O RING 46	1	PC.
017			962106-1	RETAINING RING R-28	1	PC.
018			961052-5	RETAINING RING S-12	1	PC.
019	2		211148-5	BALL BEARING 6001ZZ	1	PC.
020			253084-9	FLAT WASHER 12	1	PC.
021			317367-2	BEARING BOX	1	PC.
022			240036-9	FAN 57	1	PC.
023	2		515211-9	* ARMATURE ASS'Y 115V	1	PC.
		INC.		* Item No. 22,24-26		
	3		518148-9	* ARMATURE ASS'Y 115V	1	PC.
		INC.		* Item No. 22,24-26		
024			681656-4	INSULATION WASHER	1	PC.
025			253823-7	FLAT WASHER 7	1	PC.
026			210023-2	BALL BEARING 627DDW	1	PC.
028			421770-2	LABYRINTH RUBBER RING 22	1	PC.
029			688117-5	MAGNET SLEEVE	1	PC.
030	2		259039-2	* SELF LOCK 6	1	PC.
031			413076-2	BAFFLE PLATE	1	PC.
032			266259-1	TAPPING SCREW 4X60	2	PC.
033			344871-8	RETAINER	2	PC.
034			417237-6	* INSULATION COVER (removed)	2	PC.
035	1		626526-0	* FIELD 115V (OLD# 626521-0)	1	PC.
	2		626527-8	* FIELD 115V	1	PC.
	3		621B66-5	* FIELD 115V	1	PC.
038			852418-9	NAME PLATE F/GD0810C	1	PC.
039			266256-7	TAPPING SCREW PT3X10	4	PC.
040			643760-7	BRUSH HOLDER (OLD# 643762-3 - N/L/A)	1	PC.
041	2		194999-0	A.C. CARBON BRUSH CB-318 2PC/SET (W/ ORIGIN)	1	SET
	4		196454-8	A.C. CARBON BRUSH CB-340 2PC/SET (W/ ORIGIN)	1	SET
042			265995-6	TAPPING SCREW 4X18	2	PC.
043			687063-9	CORD CLAMP (STRAIN RELIEF)	1	PC.
044			632999-7	SWITCH BLOCK	1	PC.
045			664064-4	CORD W/PLUG 2P-18-2.5M, SJ	1	PC.
046	2		682559-5	CORD GUARD	1	PC.
047			651418-4	SWITCH ST115A-40	1	PC.
048			687113-0	COVER	1	PC.
049			816802-2	INDICATION LABEL	1	PC.

Item No	Type	Sub	Part No	Description	Qty	Unit
050	1		158191-2	* REAR COVER COMPLETE	1	PC.
		INC.	817428-3	* CAUTION LABEL	1	PC.
	2		144093-8	* REAR COVER COMPLETE	1	PC.
		INC.	817427-5	* CAUTION LABEL	1	PC.
051			265995-6	TAPPING SCREW 4X18	1	PC.
052			631390-6	CONTROLLER	1	PC.
053			417187-5	SWITCH LEVER	1	PC.
054			233071-4	COMPRESSION SPRING 4	1	PC.
055			643760-7	BRUSH HOLDER (OLD# 643762-3 - N/L/A)	1	PC.
056	2		417812-8	* MOTOR HOUSING	1	PC.
058	2		417813-6	* SWITCH KNOB	1	PC.
059			265999-8	TAPPING SCREW 4X25	4	PC.
100			654037-5	INSULATED EYE TERMINAL FT1.25-M3	2	PC.
101			652037-9	P.H. SCREW M3.5X8	2	PC.

ACCESSORIES

- See catalogue or visit www.makita.ca for more optional accessories -

A01			781203-2	WRENCH 13	1	PC.
A02			781206-6	WRENCH 19	1	PC.
A03			192985-5	SIDE HANDLE SET	1	PC.
	2	INC.	153503-4	GRIP 36 COMPLETE	1	PC.
		INC.	415485-1	GRIP BASE	1	PC.
		INC.	921919-9	HEX. BOLT M8X110	1	PC.
A04			192986-3	COLLET CONE 1/4'	1	PC.
		INC.	763650-9	COLLET CONE 1/4' - N/A as individually	1	PC.
		INC.		Item No. 1		
	Opt.		192987-1	COLLET CONE 1/8"(Optional)	1	PC.
		INC.		Item No. 1		
	Opt.		193012-1	COLLET CONE 6MM(Optional)	1	PC.
		INC.		Item No. 1		
A05			193141-0	WISE HOLDER SET (Optional)	1	PC.
A06			-----	ABRASIVE FLAP WHEELS		
A07			-----	CARBIDE BURRS		

SERVICE CHANGES

1. Changes on Armature Assy

(TI#B2975)

Item No.	Description	Type 1	Type 2	Type 3
23	Armature Assy 115V	515196-9 (N/L/A)	515211-9	518148-9
30	Stop Ring/ Self Lock	961011-9	259039-2	
35	Field 115V	626526-0		626527-8

Above parts are completely interchangeable as a set.

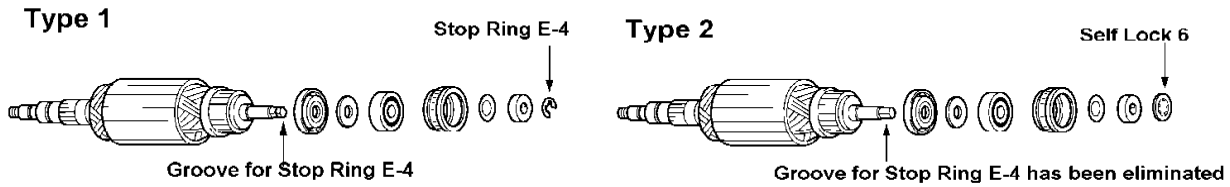

2. Changes on Motor Housing, Switch Knob and Rear Cover

(TI#B2975)

Item No.	Description	Type 1	Type 2	Type 3	Type 4
56	Motor Housing	(Complete w/ label)	155297-1 (N/L/A) (Complete w/	417812-6 (without label)	
58	Switch Knob	417188-3 (N/L/A)	417813-6		
50	Rear Cover			(Complete w/	(Complete w/

Above parts are completely interchangeable as a set.

Motor Housing & Switch Knob Type 1 → Type 2

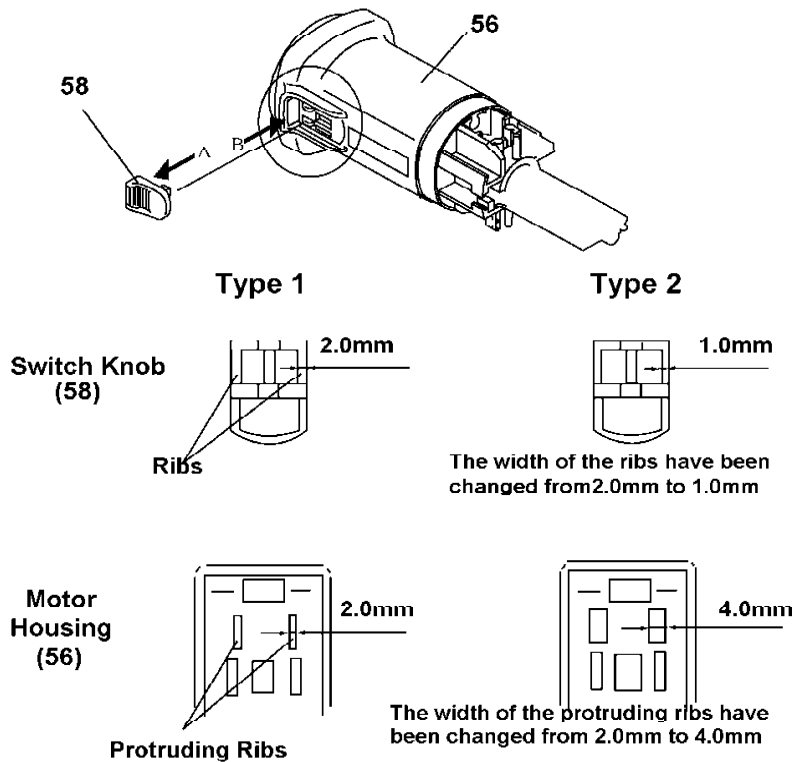

3. Changes on Field and elimination of Insulation cover

(T/I/#DH253)

Item No.	Description	Type 1	Type 2
34	INSULATION COVER	417237-6	-----
35	FIELD 115V	626527-8	621B66-5

Above parts are completely interchangeable as a set.

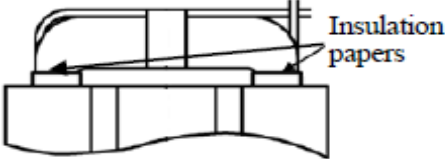
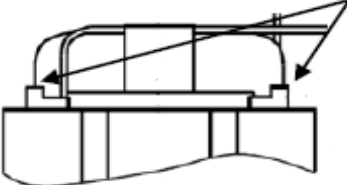
	Current	New
[1]	Insulation covers (2 pcs) 	Eliminated
[2]-[45]	 Insulation papers	 Insulation papers will be extended.